

# DESIGN OF BIODEGRADABLE PACKAGING SYSTEM FOR ELECTROLYZERS APPLYING A METHODOLOGY IMDNP

**Marisol Rico-Cortez<sup>1</sup>, Eduardo Oliva-López<sup>1</sup>, Juan M. Sandoval-Pineda<sup>2</sup>, Rosa González-Huerta<sup>3</sup>,**

*1 Instituto Politécnico Nacional, Escuela Superior de Ingeniería Mecánica y Eléctrica, Sección de Estudios de Posgrado e Investigación, Unidad Profesional "Adolfo López Mateos" Edificio 5 tercer piso; Del. Gustavo A. Madero; Col. San Pedro Zacatenco; C.P. 07738 México.*

*2 Instituto Politécnico Nacional, Escuela Superior de Ingeniería Mecánica y Eléctrica, Sección de Estudios de Posgrado e Investigación Unidad Azcapotzalco, Av. de Las Granjas 682, Azcapotzalco, Santa Catarina, 02250 Ciudad de México, D.F.*

*3 ESIQIE-IPN, Laboratorio de Foto-Electro catálisis, Unidad Profesional Adolfo López Mateos Edificio N°7, Gustavo A. Madero, Lindavista, 07738 Ciudad de México, D.F*

## **Introduction**

### **General Context**

Now a days the production of fossil fuel energy, in hand with its excessive consumption, is part of a serious and unjustified pollution environment; all together adding health problems to the population. Reducing the consumption of fossil fuel energy has become an urgent necessity to reduce the emission of carbon dioxide in the atmosphere. The harmful effects on the environment are not linked only by the combustion products, but also to its means of transportation and the sub products that they generate (solid and toxic waste). This situation aggravates, when it includes the reduction of active deposits, the over growing demand of energy, the increase of global population and its industrial development (González, 2013). The big scale production of alternative fuels, offers an opportunity, for developing countries, to reduce their dependence to petroleum imports. Although, in developed countries exist an ever growing trend for technologically based jobs that use different renewable energy sources, as well as the use of alternative fuels. In the 1970's Veziroglu and Basar developed a computational model to characterize the technical, social, economic and environmental impacts of the substitution of fossil fuels for electrolytic hydrogen, obtained by the use of solar energy, this model has been used in different studies around the world such as the case in the coast of Ceará, Brasil. For the period between 2015 and 2110, it was developed a study in Brasil, which includes three aspects: total energy demand, hydrogen production and fossil fuel demand. According to this study in a slow introduction panorama of hydrogen, the fossil fuel demand grows until the year 2040, after that, the consumption of fuels decreases until it is zero in the year 2065. Until then, it is projected that hydrogen will have already replaced it. In a fast introduction scenario, the dependence from fossil fuels would be achieved in ten years less, it means, by the year 2055. It is estimated that, by the year 2035 that replacement will generate US 3.4 million (Sacramento, 2013). Hydrogen energy has been exploited as a renewable energy storage system, to produce electric power and inject it to and internal combustion engine, which has been harnessed by vehicles that use it in its liquid form, hydrides or methanol for small automobiles and compression for big vehicles (Gutiérrez, 2005). As electricity, hydrogen can be produced from different resources including fossil fuels, renewable energy and nuclear energy. Hydrogen can develop from electric power using electrolyzers and hydrogen electricity using fuel cells. Electrolyzers are hydrogen and oxygen generating devices, using a sodium or potassium hydroxide electrolytic substance, through the electrolysis process. This process consists of separating the elements within a compound by means of electrical flow. The electrolyser generates a decomposition of water, this decomposition results in two partial reactions in the electrodes, hydrogen is produced in the cathode and oxygen is released in the anode. The

capture of electrons by the cations in the cathode (a reduction) and the liberation of electrons by the anions in the anode (an oxidation) takes place. Important economic sectors, such as, transportation, maritime, mining, agriculture, are interested in the use of hydrogen by electrolyzers, this is the reason why developing a sustainable packaging system is extremely necessary for its transportation and distribution due to the fragility of these devices. The next section of this paper, presents the design concept development of the packaging system, using integral model for designing new products (Rico, 2016). Subsequently, the concept development and prototype development are exposed. Finally, the conclusions and the future works are shown.

## **Packaging System**

### **Background**

Packaging is a core element for the logistics of any product, its quality depends on the function to protect the product until its final destination. Companies see packaging as an investment and it is as important as the product itself (Nilsson, 2015). Packaging is affected by the requirements in every step of the supply chain, from its production, to its final user. In logistics, the requirements involve transportation, handling and storage. Within these requirements are, information about the product, volume, weight, product quantity, dimensions and the easy of handling, the last one involves package ergonomics. According to (Nilsson, 2015) packaging is a silent seller and he describes it as a powerful selling instrument that highlights the qualities and advantages of the product. The added value of a package system is to reunite all the requirements mentioned before, since, for example a package does not contain the complete information (specifications, weight, dimensions, stowage capacity, etc.), and it would affect the next steps of the logistics chain, such small details, and result in major problems in the delivery.

### **Integral Model for Designing New Products**

Integral Model for Designing New Products IMDNP, (Rico, 2016) is based on the numerical succession found by the Italian mathematician Fibonacci during the Middle Age. (Koshy, 2001) (Benjamin, 2003.) (Miller, 2012). His studies have contributed in different areas, such as, Architecture, Statistics, Applied Mathematics, Cybernetics (Assimakis, 2013) (Saari, 2014), among others, and now it has become an inspirational source for analyzing processes involve in the development of this project, including functional methodologies such the case of the Quality Function Deployment (QFD). The information obtained to accomplish the research in this project is derived from different bibliographical sources, referring to packaging concepts, however, there were not found publications that contribute to the packaging analysis for such specialized product as the electrolyzers, for that reason, the IMDNP is used. Figure 1. Illustrates its first phase, which has 6 steps:

Origin – Client – Maritime transportation  
Market Analysis – Requirements – Specifications – QFD results  
Design Tools. – Brain storming,  
Design Concept – Fibonacci succession, Alternative Development  
Experimental and Numerical Analysis –Mechanical Properties Analysis FEM  
Final Prototype - Manufacturing

The first step originates with the customer needs. The second step consists of analyzing the market, obtaining a list of requirements and specifications (Table 1), this is done, through the QFD quality matrix, which is classified in categories according to the necessities to accomplish. (Table 2.) Once these requirements are classified, they are used to perform a brainstorming exercises (Third step). In the fourth step, the design alternatives are elaborated. In the fifth step, it is developed the experimental and numerical analysis from the selected design concept, with the chosen material and specifications established through the Finite Element Method FEM solve by ANSYS®. For effects on this paper, this step is only mentioned because it requires a specific analysis, which will be published in future works. At last, in the sixth step, the final prototype model is manufactured, scale 1:1.

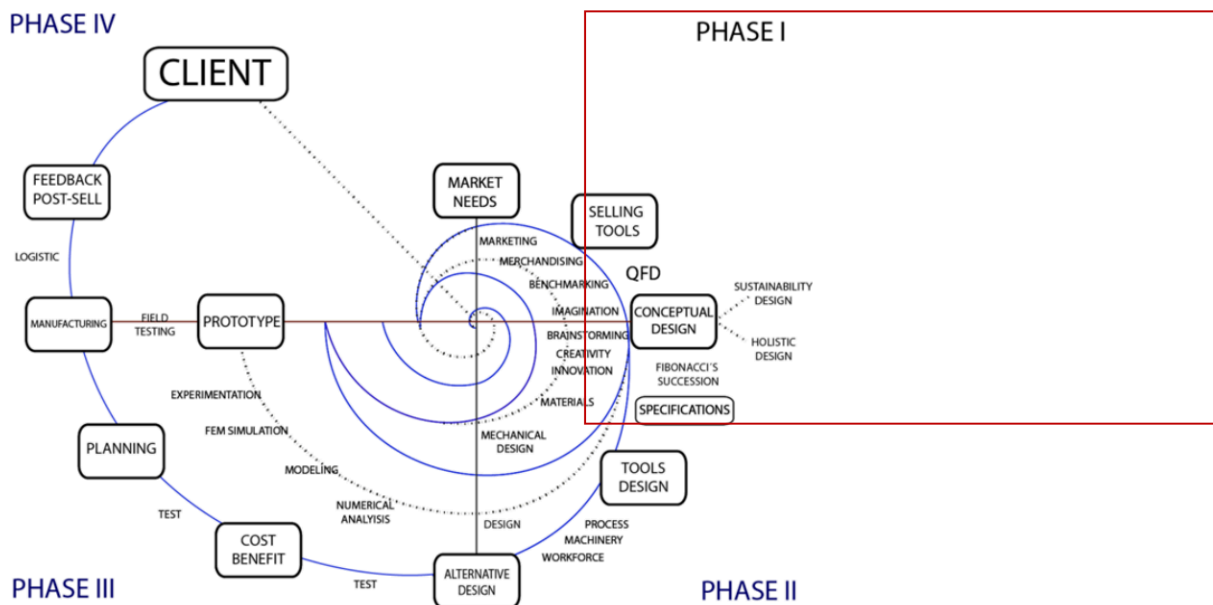

Figure 1. Integral Model for Designing New products (IMDNP)

### Market

Maritime transportation contributes in a very important way to the international economic growth considered the spine of global commerce, 70% of its value is move by boat through parts from around the world. Worldwide, global commerce has growth 3.7% while maritime commerce 3.5% annual average. Likewise in Mexico it is seen an 11.3% continuously growth and linked to maritime with 131 countries and more than 490 destinations around the 5 continents. Representing the major energy consumption (44.8%). Indeed the necessity of the goal market comes up by starting the distribution of electrolyzers in the Mexican maritime ports.

### Market Requirements

In Table 1. It is shown the market requirements, which have been classified in four criteria: use, function, design and identification. In use requirements it is taken into consideration the direct interaction, packaging – user; In function requirements, physical and mechanical packaging with specific properties are classified; In design requirements appropriate aesthetic characteristics for the product and finally the identification requirements have to do with brand image and product specifications for its marketability. For effects on this step of the research, they are only mentioned as they will be used in future works. Once the requirements are classified, the QFD matrix is developed. Table 2 shows the obtained results of the analysis, applied to market necessities, from which, resistance, easy handling, attractiveness, ergonomics and easy merchandise where the major percentage characteristics, 17%, 11%, 9%, 9%, 9% y 6%, respectively.

No	USE	FUNCTION	DESIGN	ID
1	Dimension	Resistant to	Attractive	Print
2	Practicality	stowage	Innovative	Ink tones
3	Secure	Resistant to Impact	Ergonomic	Finish
4	Easy to handle	Stable	Anatomic	Color
5	Easy to transport	Light	Easy to	
6	Anthropometric	Biodegradable	Manufacturing	

Table 1. Classification of the requirements of the market.

### Product Description (electrolyzer)

Alkaline electrolyzers are extremely delicate devices; the reason is that they contain a Potassium or Sodium hydroxide watery alkaline solutions a highly corrosive electrolyte. The alkaline electrolyser is manufactured with two external aluminum caps of ¼” thickness, the electrodes are made of stainless steel sheet 10 cal., separated in between by a 2mm thickness Teflon plate, joint together with six fine string screws ¼” diameter. The general dimensions of the product are 150mm diameter by 35mm thickness.

Requirements of the Client		Evaluation Criteria											Percentage
		Client priority	Material Specifications	Material Requirements	Customer satisfaction	Quality indicators	Machinery and Tools	Product design	Structural design	Process	Manufacturing operations	Packaging	
1	Dimensions	5	5	5	5	1	5	5	5	5	4	5	3%
2	Practicality	3	5	5	5	5	5	3	3	5	5	0	2%
3	Sure	4	5	5	5	5	3	4	4	4	4	0	<b>11%</b>
4	Easy to handle	5	4	4	3	3	0	1	5	0	5	5	4%
5	Transportation	3	3	0	3	4	1	0	0	4	1	5	<b>6%</b>
6	Anthropometric	4	4	4	5	4	4	4	5	1	3	0	3%
7	Resistant to stowage	5	5	5	5	5	4	3	5	5	5	0	<b>17%</b>
8	Resistant to impact	5	5	5	4	5	0	0	5	0	0	5	<b>9%</b>
9	Stable	5	5	5	4	5	0	5	5	0	0	0	3%
10	Light	3	5	3	1	3	0	0	5	0	5	5	1%
11	Biodegradable	4	5	4	2	1	0	0	0	0	0	5	2%
12	Attractive	5	2	1	5	5	0	5	0	0	0	0	<b>9%</b>
13	Innovative	5	4	4	5	4	3	5	5	4	4	0	4%
14	Ergonomic	5	1	1	5	4	3	5	5	4	4	0	<b>9%</b>
15	Anatomic	5	3	3	4	5	0	5	5	0	0	0	3%
16	Easy to manufacturing	5	5	5	4	5	4	3	3	5	5	0	<b>6%</b>
17	Print	3	4	4	3	5	5	1	0	5	5	0	1%
18	Ink tones	3	1	1	3	4	5	0	0	5	5	0	1%
19	Finish	5	1	5	3	5	0	0	5	5	0	0	3%
20	Colour	3	1	1	3	3	5	5	0	0	0	0	1%
												100%	

Table 2. Weighting matrix of the requirements resulting from the application of QFD

### Design Concept

The design concept is oriented on creating perfect mathematic designs leading to its maximum level of proportion, which makes a nice and functional object, is in this stage where imagination and creativity combine. Also, a system was designed under an eco-design packaging concept, which consists of analyzing the packaging life cycle, considering every step of the process, from development, production, distribution, and use, to its disposal in such way that the packaging system can renew, reuse or discard in biodegradable recycling deposits.



Figure 2- Product – alkaline electrolyzer in performance analysis. Fuente: (Fuentes, 2016)

### Alternatives selection

According to Table 2. The most important requirements are: Resistance, easy handling, attractiveness, ergonomic and ease of production. There were three design alternatives created for this project with different approaches, then, the design concept is selected through an evaluation matrix using two criteria, (Table 3.) The next phase is material selection and specifications establishment, like dimensions, stowage, and capacity, among others. In this selection a compatible material research is made, in this case, for electrolyzers, it must have the same sustainable and ecological characteristics that are required. Three alternatives were developed, with A1, A2, and A3 nomenclature, respectively, which were analyzed under the characteristics of each alternative within the requirements mentioned before. The results of the analysis are shown in Table 3. Two evaluation criteria's were established:

(0) does not satisfy the requirement and (5) that meets satisfactorily the requirement. The highest score alternative corresponds to A3 with 92 points (Table 3).

ID	Requirements	A1	A2	A3
1	Dimensions	5	5	5
2	Practicality	1	4	4
3	Secure	3	4	5
4	Easy to handle	3	3	5
5	Transportation	3	3	5
6	Anthropometric	2	3	5
7	Resistant to stowage	4	3	5
8	Resistant to impact	2	3	5
9	Stable	3	4	5
10	Light	3	4	4
11	Biodegradable	5	5	5
12	Attractive	3	5	4
13	Innovative	3	5	4
14	Ergonomic	3	4	5
15	Anatomic	2	4	5
16	Easy to manufacturing	4	4	5
17	Print	4	1	4
18	Ink tones	3	1	4
19	Finish	3	2	4
20	Colour	3	1	4
		62	68	92

Table 3. Matrix selection of alternatives

**Development of selected alternative**

Figure 3 shows the result of the ergonomic development of the design concept, whose proportion corresponds to the represented relation of the golden rectangle. The Ec. (1) shows the start of proportion, in which a = 1

$$a + \varphi = b \dots\dots\dots Ec (1)$$

$$\varphi = \frac{1 + \sqrt{5}}{2} \dots\dots\dots Ec (2)$$

Proportion is a highly important characteristic due to the fragility of the product. An ergonomic appropriate design allows a proper handling of the packaging and stowage arrangement, since its proportion adapts to the stacking of products inside the transportation unit.

**Materials**

For companies, environmental impact is an extremely important factor in packaging designs, since it has to include the packaging life cycle with its feasibility to degrade without causing environmental problems or even better, its feasibility to recycle, this is why, and it is manufactured with cellulose fibre materials, made up from water base polymers.

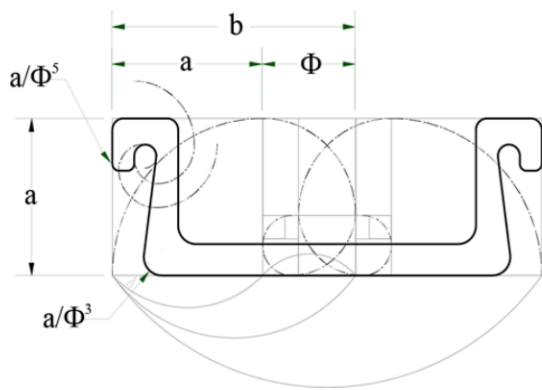

Figure 3. Conceptual Design

**Prototype Elaboration**

For the prototype elaboration two types of structure were manufactured, the first one corresponds to the lateral caps and the second one forms the central structure that, when joint together, they form the packaging. These pieces were manufactured with 4mm corrugated cardboard made of cellulose fibres material in flute shape B. Figure 4 shows the structures manufactured with laser cut model CO2 high precision laser cutting. Subsequently Figure 5 Shows the structure assembly, whose components were joint with a water base polymer. Figure 6, present the assembly packaging with 14 electrolyzers.

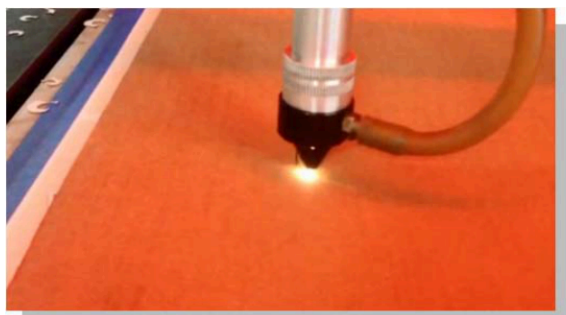

Figure 4. Laser cutting process

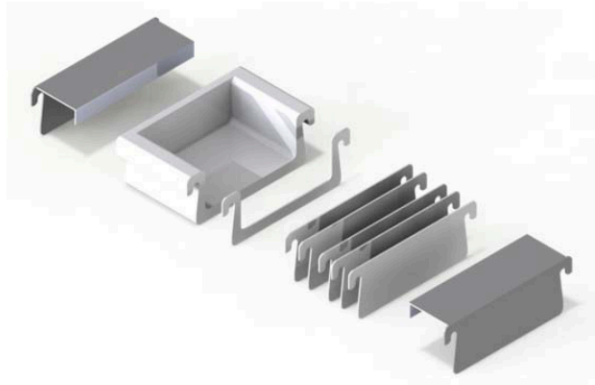

Figure 5. Assembly of packaging

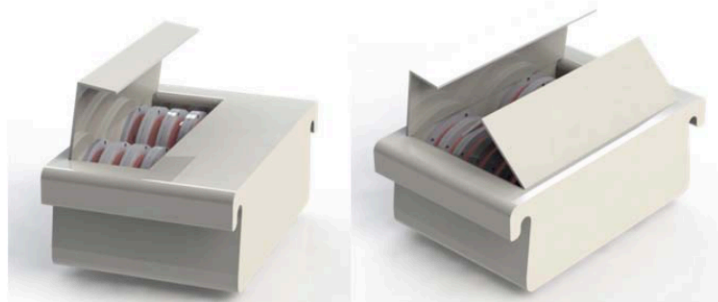

Figure 6.-Sustainable packaging with product



Figure 8. Result Analysis Ergonomic Sustainable Packaging for electrolyzers

### **Results**

The packaging structure is designed from three different pieces only. Optimizing in an enormous way the assembly and production process. Figure 8 depicts the final prototype of the packaging system, which shows an aesthetic appearance and resistance. The purpose of this study is to consider the proportional aspects of the product, the synergy within the harmony and, at the same time, the functionality and use of the product. Figure 9 illustrates the result of the ergonomic study. On the other hand, the contribution of this packaging system ensures the security of the product in its logistics process and delivery to final users, meeting the entire list of requirements.

### **Conclusion**

A prototype of a sustainable packaging system was obtained, with a perfect mathematic proportion, ergonomics, highly resistance to stowage, with an auto-ventilated system, anatomical to the product, anthropometric for the user and completely recyclable, which function is to protect electrolyzers through logistics, from the production departure, storage, transportation, distribution, up to the

customer delivery applying the Integral Model for Designing New products, since it is an excellent tool for creating designing alternatives by object proportions, for this reason the results are optimum and reliable for the for the management of this system. The packaging structure is designed from three different pieces only. Optimizing in an enormous way the assembly and production process. However, this work only covered the first stage of the IMDNP, meaning this it is in the future to analyze and evaluate in works to come the following stages: Numerical analysis and experimental system by FEM, test analysis and risks, costs analysis, planning and manufacturing feasibility.

### **Acknowledgments**

1. Government of México, 2. Instituto Politécnico Nacional, Escuela Superior de Ingeniería Mecánica y Eléctrica U-Zacatenco y Azcapotzalco 3. Project SIP No. 20160414-20160416, 4. CONACYT Consejo Nacional de Ciencia y Tecnología and the organizers of the event by its attentive invitation.

### **References**

- Assimakis, N. L. f. (2013), "Golden section and Fibonacci sequence". *Signal Processing*, pp. 721-730.
- Benjamin, A. T. (2003), "The Fibonacci Numbers- Exposed More Discretely". *Mathematics Magazine*, pp. 182-192.
- Beno, F., Millet, D., & Glatard Mahut, S. (2012). "Using eco-design tools: An overview of experts's practice". *Design studies*, 34, 345-377.
- Do Sacramento, (2013), "Feasibility study for the transition towards a hydrogen economy: A case study in Brazil". *Energy Policy*, Vol. 62, pp. 3-9.
- Fuentes Coutiño, J. A., (2016), "Diseño, manufactura y caracterización del prototipo de un reactor oxihidrógeno arreglo paralelo para generar un flujo de 250 ml/mn". México: Tesis de Maestría, Instituto Politécnico Nacional, ESIME-U A.
- González-Huerta, R. G., (2013), "Hidrógeno producción y almacenamiento: Retos hacia su uso como vector energético sustentable". *CreateSpace*.
- Gutiérrez Jodra, L., (2005), "El hidrógeno, combustible del futuro". *R. Academia de Ciencias Exactas, Físicas y Naturales*, Vol. 99, pp. 49-67.
- Hayes, R., (1979), "Link manufacturing process and producto life cycles". *Harvard Business Review*.
- Koshy, T., (2001), "Fibonacci and Lucas Numbers with Applications". *New York, Wiley*.
- L. Blizzard, J., & E. Klotz, L. (2012). "A framework for sustainable whole systems design" *Design Studies*, 33, 456-479. doi:10.1016/j.destud.2012.03.001
- Matthias N., W. T. S. R., (2012), "A Hydrogen Direct Injection Engine Concept that Exceeds DOE Light-Duty Efficiency Targets". *International Journal Engines*.
- Miller, S. J., (2012), "From Fibonacci numbers to central limit type theorems". *Journal of Combinatorial Theory*, pp. 1398-1413.
- Nilsson, F. M. F. M. a. K. J., (2015), "Globally standardised versus locally adapted packaging Communications". *International Journal o Retail & Distribution Management*, Vol. 20, pp. 396-414.
- Rainbird, M. (2004). "Demand and supply chains: the value catalyst". *International Journal of Physical Distribution and Logistics Management*, 34(3), 230-250.
- Rico, M. C., (2016). "Innovating the Design Process inspired by the Fibonacci Sequence". *IPN*.
- Saari, K., (2014), "Lyndon words and Fibonacci numbers". *Journal of Combinatorial Theory Series A*, pp. 34-44.